



**PRE- BID CONFERENCE CALL
CALL HELD ON 5/23/ 3:00 PM CDT
WENDY'S - #12246
Highway 87 (South Dumas Ave.) & 1st Street
Dumas, TX 78029**

- GC CONTRACT WILL BE WITH TOOT N TOTUM
 - SAMPLE GC CONTRACT THAT WILL BE USED ATTACHED IN BID DOCUMENTS
- GC TO INCLUDE BUILDERS RISK INSURANCE
- WENDY'S MANAGING PROJECT ON BEHALF OF HERITAGE PARTNERS. CONTACT IS: MAT KNUPP
- BIDS DUE, UPLOADED IN GATEWAY 6/13/19 2:00 PM CDT
 - GC BID SHEET INCLUDED IN BID DOCS TO BE SEPERATLEY COMPLETED AND E MAILED TO MAT.KNUPP@WENDYS.COM

- BUILDING DESIGN IS WENDY'S PROTOTYPE SMART 55 SQE. A LIST OF SIMILAR STORES CAN BE PROVIDED SHOULD BIDDERS WISH TO SEE A SIMILAR BUILDING
- BUILDING PERMIT HAS BEEN SUBMITTED. GC WILL PICK UP AND PAY FOR PERMIT. INVOICE COST AS A SEPERATE INVOICE, NO MARK UP. DO NOT INCLUDE COSTS IN BID
- SIGN PERMITS BY WENDY'S.
- ALL OTHER PERMITS ARE BY GC AND/OR SUBCONTRACTORS. ANY COSTS TO BE INCLUDED IN PROPOSAL
- CONSTRUCTION DURATION IS **91 CALENDAR DAYS**, START OF CONSTRUCTION TO TURNOVER TO OPERATIONS
- TURNOVER TO OPERATIONS PROJECT EXPECTATIONS
 - PROJECT 100% COMPLETE EXCEPT FOR MINOR PUNCHLIST ITEMS
 - SITE PROFFESIONALLY CLEANED
 - ALL CONSTRUCTION MATERIALS, EQUIPEMENT, WASTE, ETC. HAS BEEN REMOVED
 - ALL INSPECTIONS COMPLETE AND SIGNED OFF
 - RECEIPT OF CERTIFICATE OF OCCUPANCY
- GAS & ELECTRIC APPLICATIONS HAVE BEEN MADE. GC TO ASSIST WITH APPLICATION AND IS RESPNSIBLE TO SCHEDULE/COORDINATE INSTALLATION
- TEMPORARY POWER IS BY GC
- GC REQUIRE TO MAKE APPLICATION/PAY TAP FEES FOR WATER SERVICE, SEWER SERVICE, ETC.
- EXHIBIT 'A' (DRAWING/EXHIBIT LIST) WILL BECOME A PART OF THE GC CONTRACT. MAKE SURE YOU HAVE THE CORRECT DRAWINGS. INCLUDE LISTING WITH YOUR PROPOSAL



- EXHIBIT 'B' WILL BECOME A PART OF THE GC CONTRACT
 - REVIEW EXHIBIT B
 - NOT SPECIFICALLY CALLED OUT IN EXHIBIT 'B'
 - GC RESPONSIBLE TO COMPLETE CONDENSATE LINE IN ICS WALK IN BOX
 - ICS WALK IN BOX INTERNAL RAMP, SS BASE AND FLASHING INSTALLED BY GC
- GEOTECH REPORT
 - BUILDING AREA EXCAVATION/FILL; 4.2
 - PAVEMENT AREA STABILIZATION; 6.0
 - ALL REQUIRED SOIL TESTING/COMPACTION BY GC
- PROVIDE UNIT PRICING FOR REMOVAL OF ADDITIONAL UNSTABLE SOIL AND UNIT PRICE TO IMPORT & PLACE COMPACTED FILL (\$/CY)
- INCLUDE 1 YEAR LABOR WARRANTY FOR RTU'S SUPPLIED BY WENDY'S
- RTU BASIS OF DESIGN IS TRANE, MAKE SURE SWITCHGEAR BID REFLECTS TRANE
- NOTE IN PROPOSAL, WHICH MANUFACTURER OF SWITCHGEAR YOU ARE PROVIDING: WESCO OR CPI
- DISCUSS DETAIL AT TOP OF SWITCHGEAR
- INCLUDE TRANSFORMER PAD, SECONDARY CONDUIT & WIRE; ASSUME 50 LF
- SPRING RELEASE DRAWING UPDATES
 - ELECTRICAL AT CENTER ISLAND
- GC TO PROVIDE 2- 2" SLEEVES FOR IT/PHONE (100 LF EACH)
- REVIEW CLARIFICATION SHEET
- STOOL SEATING CORED AND INSTALLED BY GC; SEE CODED NOTE 1 SHEET EQ1.1
- WASHROOM SINKS FURNISHED AND INSTALLED BY GC
- INCLUDE WATER TAP/CONNECTION, INCLUDING BACKFLOW FOR IRRIGATION SYSTEM. INCLUDE OUTLET FOR IRRIGATION TIME CLOCK
- INCLUDE INSTALLATION OF GREASE TANK ENCLOSURE PROVIDED BY OTHERS
- ADA SURVEY WILL BE COMPLETED AT THE END OF THE PROJECT BY WENDY'S
- PAINT ALL SUBSTRATE BEHIND WT-2, BLACK PRIOR TO INSTALL OF WT-2
- MENUBOARD FOOTINGS, DIRECTIONAL FOOTINGS, PRE SELL BOARD FOOTINGS BY OTHERS
- OCD CANOPY FOOTING BY GC'S
- INCLUDE ELECTRIC CIRCUIT AND HOOK UP OF HEAT TAPE FOR AWNINGS
- PROVIDE ALTERNATE PRICE FOR NICHIIA SIDING IN LIEU OF EIFS.
- INCLUDE GC SUPT, ELECTRICIAN, PLUMBER & HVAC TRADESMAN TO BE AT STORE ON OPENING DAY TO RESOLVE ANY ISSUES THAT COME UP
- PARKING LOT ALTERNATE PRICING
 - CONCRETE
 - CONCRETE AT ADA PARKING & TRAVEL PATH
- HJC
- HVAC "DUMP BOXES" SHOWN ON M2 ARE TO BE FIELD FABRICATED BY GC/HVAC SUB. EGGER NO LONGER MANUFACTURES

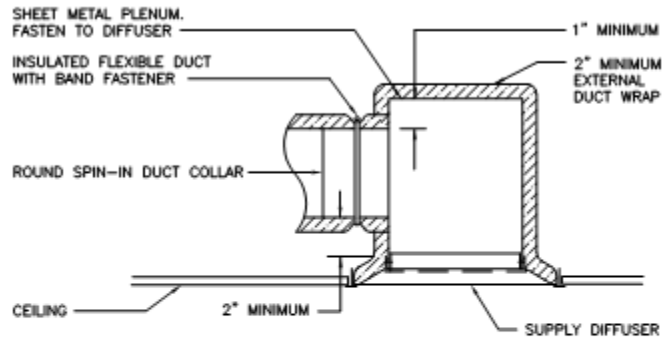

NOTE: REFER TO PLANS FOR ROUND DUCT SIZE.

DUMP BOX DIFFUSER DETAIL (8)
NTS

- ALL HVAC DIFFUSERS, REGISTERS, GRILLS, ETC FURNISHED/INSTALLED BY GC/HVAC SUB
- OTHER/QUESTIONS